

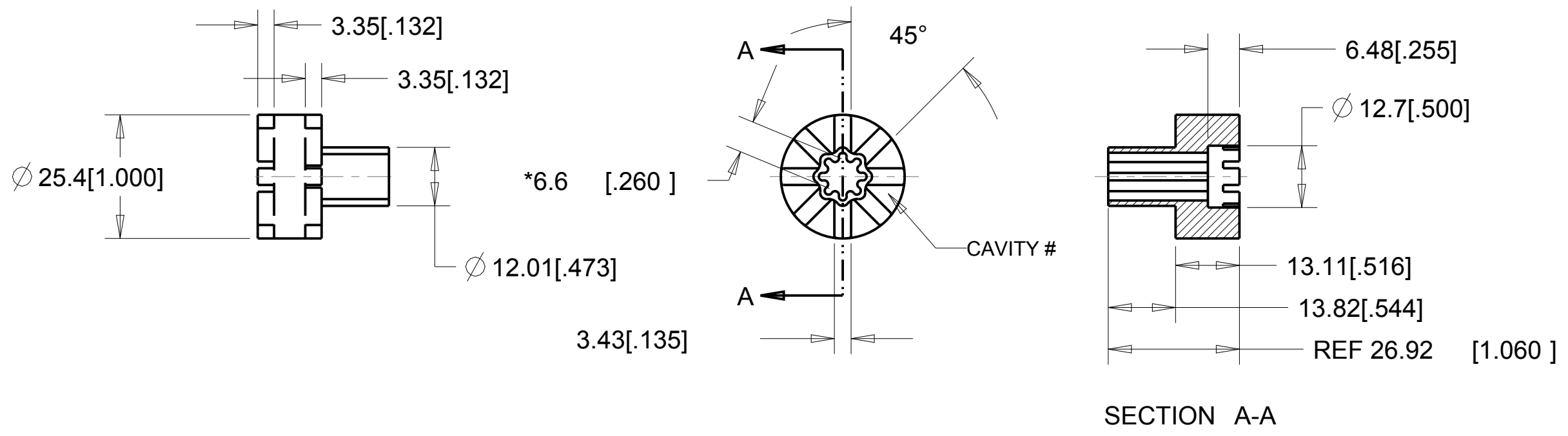

REVISIONS				
DRAWN	REV	DESCRIPTION	DATE	APPROVED
DH	00	ORIGINAL	11-30-98	DC
KP/TC	01	UPDATED FORMAT, ADDED WEIGHT, RIB HEIGHT DIMS, CHANGED DIM 26.92 TO REFERENCE, ADDED -X TO NAMING CONVENTION, CAVITY LOCATION AND UPDATED TOLERANCES.	9-8-11	MS



B-435-2775	V-2775
B-435-2750	V-2750
B-435-2725	V-2725
B-435-2599	V-2599
B-435-2590	V-2590
B-435-2575	V-2575
B-435-2550	V-2550
B-435-2525	V-2525
B-435-2375	V-2375
B-435-2350	V-2350
B-435-2325	V-2325
B-435-8	C-8002
B-435-3	C-1100
B-435-2	C-1105
B-435-1	C-1002
PART NUMBER	MATERIAL

RANGE	TOL
0 < DIM <= 2 [.078]	± 0.15 [.006]
2 [.078] < DIM <= 25 [.98]	± 0.25 [.010]
25 [.98] < DIM <= 50 [1.969]	± 0.4 [.016]
50 [1.969] < DIM	± 0.6 [.024]

- 3. MAX DRAFT: 2°
- 2. CRITICAL DIMENSIONS SHALL HAVE Cpk VALUE >= 1.33 WITH ONGOING SPC DATA REQUIRED.
- 1. CRITICAL DIMENSIONS ARE MARKED WITH "\*\*\*".

NOTES:

UNLESS OTHERWISE SPECIFIED UNITS ARE: MM [IN] TOLERANCE FOR ANGLES: ± 0.0 °	MATERIAL: SEE TABLE ON LEFT	AEARO TECHNOLOGIES LLC * a 3M company		
	ALLOWABLE FLASH: .12 MM [.005]	QUALITY CONTROL: MUST COMPLY WITH E-A-R SPECIALTY COMPOSITES SUPPLIER QUALITY MANUAL REQUIREMENTS	TITLE GROMMET - RIBBED	
GATE: ±.25 MM [.010]	NOTES: ANY FEATURE NOT DIMENSIONED IN PRINT MUST BE VISIBLY PRESENT, UTILIZE 3D CAD FOR CREATION	SIZE B	DRAWING NO. B-435-X	PAGE NO. 1 OF 1
6.02 GRAM REF				

1

2

3

4