



MAX6616 Evaluation Kit/Evaluation System

General Description

The MAX6616 evaluation system (EV system) consists of a MAX6616 evaluation kit (EV kit) and a Maxim CMODUSB command module.

The MAX6616 EV kit is a fully assembled and tested circuit board that evaluates the MAX6616 dual-channel temperature monitor with fan-speed controller.

Order the complete EV system (MAX6616EVCMODU) for a comprehensive evaluation of the MAX6616 using a PC. Order the EV kit (MAX6616EVKIT) if the CMODUSB command module has already been purchased with a previous Maxim EV system or for custom use in other microcontroller-based (μ C) systems.

The EV kit comes with the MAX6616AEG installed.

Component List

MAX6616 EV Kit

DESIGNATION	QTY	DESCRIPTION
C1–C6	6	0.1 μ F \pm 15%, 16V X7R ceramic capacitors (0603) TDK C1608X7R1C104K
C7	1	10 μ F \pm 15%, 10V X5R ceramic capacitors (0805) TDK C2012X5R1A106K
J1, J2	2	3-pin headers, 0.1in pitch, vertical, friction lock
J3	1	20-pin, 2 x 10, right-angle female receptacle
J4, JU2	2	3-pin single-row headers
J5, J6, JU4	3	2-pin single-row headers
J7	1	10-pin double-row header (2 x 5)
JU1	1	6-pin double-row header (2 x 3)
JU3	0	Not installed
N1, N2	2	n-channel 1.25W, 2.5V MOSFETs (SOT23) Vishay Si2302ADS
R1–R4	4	4.7k Ω \pm 5% resistors (0603)

Windows is a registered trademark of Microsoft Corp.

SMBus is a trademark of the Intel Corporation.

Features

- ◆ Two Thermistor Inputs
- ◆ Local Temperature Sensor
- ◆ Six GPIOs
- ◆ Two PWM Outputs for Fan-Speed Control
- ◆ Programmable Fan-Control Characteristics
- ◆ Automatic Fan Spin-Up Ensures Fan Start
- ◆ Nine Pin-Programmable SMBus™/I²C Addresses
- ◆ Proven PC Board Layout
- ◆ Windows® 98SE/2000/XP-Compatible Evaluation Software
- ◆ Fully Assembled and Tested

Ordering Information

PART	TYPE	INTERFACE
MAX6616EVKIT	EV kit	User-supplied I ² C master
MAX6616EVCMODU	EV system	Windows software

Note: The MAX6616 EV kit software is included with the MAX6616 EV kit but is designed for use with the complete EV system. The EV system includes both the Maxim command module and the EV kit. If the Windows software will not be used, the EV kit board can be purchased without the Maxim command module.

Evaluate: MAX6616



MAX6616 Evaluation Kit/Evaluation System

Component List (Continued)

MAX6616 EV Kit

DESIGNATION	QTY	DESCRIPTION
R5, R6	2	1.6k Ω \pm 1% resistors (0603)
R7	1	Thermistor BetaTHERM 10K3A1
R8	1	10k Ω \pm 1% resistor (0603)
R9–R16	8	10k Ω \pm 5% resistors (0603)
R17, R18	0	Not installed
TP1	0	Not installed
U1	1	MAX6616AEG (24-pin QSOP)
—	2	Shunts
—	1	MAX6616 EV kit PC board
—	1	MAX6616 EV kit software (CD-ROM)

MAX6616 EV System

PART	QTY	DESCRIPTION
MAX6616EVKIT	1	MAX6616 EV kit
CMODUSB	1	CMODUSB command module

Component Suppliers

SUPPLIER	PHONE	WEBSITE
TDK	847-803-6100	www.component.tdk.com
Vishay	408-988-8000	www.vishay.com

Note: Indicate you are using the MAX6616 when contacting these component suppliers.

MAX6616 EV Kit Files

FILE	DESCRIPTION
INSTALL.EXE	Installs the EV kit files on your computer
MAX6616.EXE	Application program
HELPPFILE.HTM	Help file
FTD2XX.INF	USB device driver file
UNINST.INI	Uninstalls the EV kit software

Quick Start

Recommended Equipment

- The MAX6616EVCMDU EV system
 - MAX6616EVKIT
 - CMODUSB command module (USB cable included)
- Power supply: +12V at 3A (FVCC)
- Two 12V cooling fans with tachometer (with a 3-pin 0.1in pitch and friction lock connector, $I_{MAX} < 1.2A$)
- A user-supplied Windows 98SE/2000/XP PC
- A spare USB port on the PC

Procedure

Do not turn on the power until all connections are complete.

- On the CMODUSB command module, ensure the shunt of J1 is in the 2-3 position (3.3V).
- Enable the I²C pullup resistors on the CMODUSB command module by setting the DIP switches (SW1 on the CMODUSB board) to the **ON** position.
- For the MAX6616 EV kit, ensure the shunts are in the default positions as follows:
 - JU1: Open (I²C address = 0x54)
 - JU2: 1-2 (set POR state of the GPIO0 to high)
 - JU3: 1-2 (CMODUSB provide power to the MAX6616 EV kit)
- Carefully connect the boards by aligning the MAX6616 EV kit's 20-pin connector with the 20-pin header of the CMODUSB command module. Gently press them together. The two boards should be flush against each other.
- Plug the first fan to connector J1 (FAN1).
- Plug the second fan to connector J2 (FAN2).
- Set the power supply to +12V, and then turn off the power supply.
- Connect the (+) power terminal of the power supply to the FVCC pad and the power supply (-) power terminal to the GND pad next to the FVCC pad.
- Turn on the power supply.
- Install the MAX6616 evaluation software on your computer by running the INSTALL.EXE program on the installation CD-ROM. The program files are copied and icons are created for them in the Windows **Start** Menu.
- Connect the included USB cable from the PC to the CMODUSB command module. A **Building Driver Database** window pops up in addition to a **New Hardware Found** message. If you do not see a window that is similar to the one described above after 30 seconds, then remove the USB cable from the CMODUSB command module and reconnect it again. Administrator privileges are required to install the USB device driver on Windows 2000 and XP.
- Follow the directions of the **Add New Hardware Wizard** to install the USB device driver. Choose the **Search for the best driver for your device** option. Specify the location of the device driver to be **C:\Program Files\MAX6616** using the **Browse** button.
- Start the MAX6616 EV kit software by opening its icon in the **Start** Menu.

MAX6616 Evaluation Kit/Evaluation System

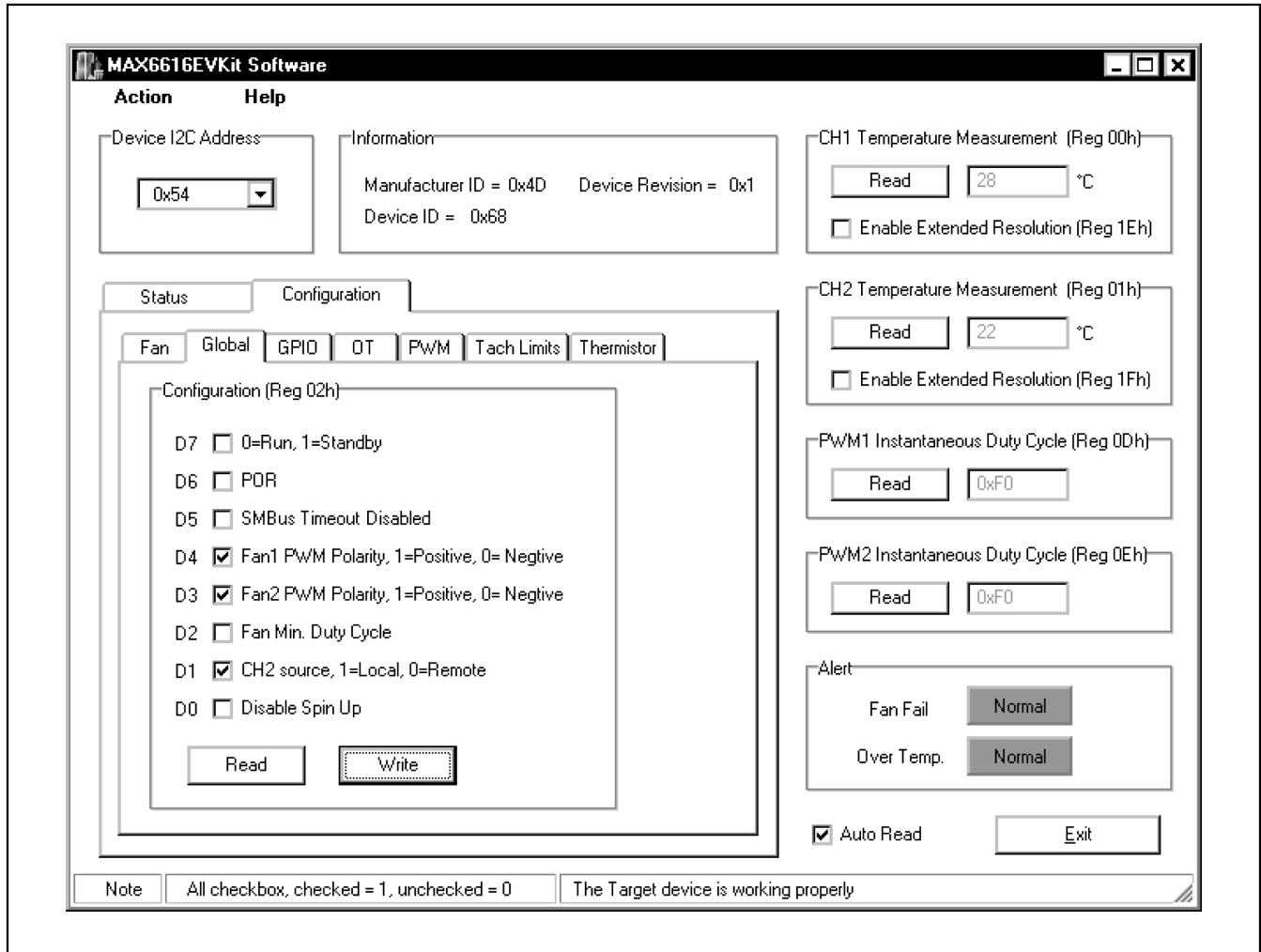

Figure 1. MAX6616 Evaluation Software Main Window

- 14) Select the **Configuration** tab, **Global** subtab, click on the checkbox **D1**, and then press the **Write** button.
- 15) Click on the **Enable Extended Resolution** checkbox of both **CH1** and **CH2 Temperature Measurement** panels.
- 16) Click on the **Auto Read** checkbox on the lower left of the main window. The current temperature is updated on the top left of the main window every second.

Detailed Description of Software

The evaluation software's main window shown in Figure 1 displays the device I²C address, device information, and current temperature of CH1 and CH2, instantaneous duty cycle for both PWM1 and PWM2. On the lower left of the main window, there are two tabs named **Status** and **Configuration** that contain most of the MAX6616 internal registers. The **Alert** panel contains the FAN_FAIL and OT output pins status and is located at the lower right of the main window.

MAX6616 Evaluation Kit/Evaluation System

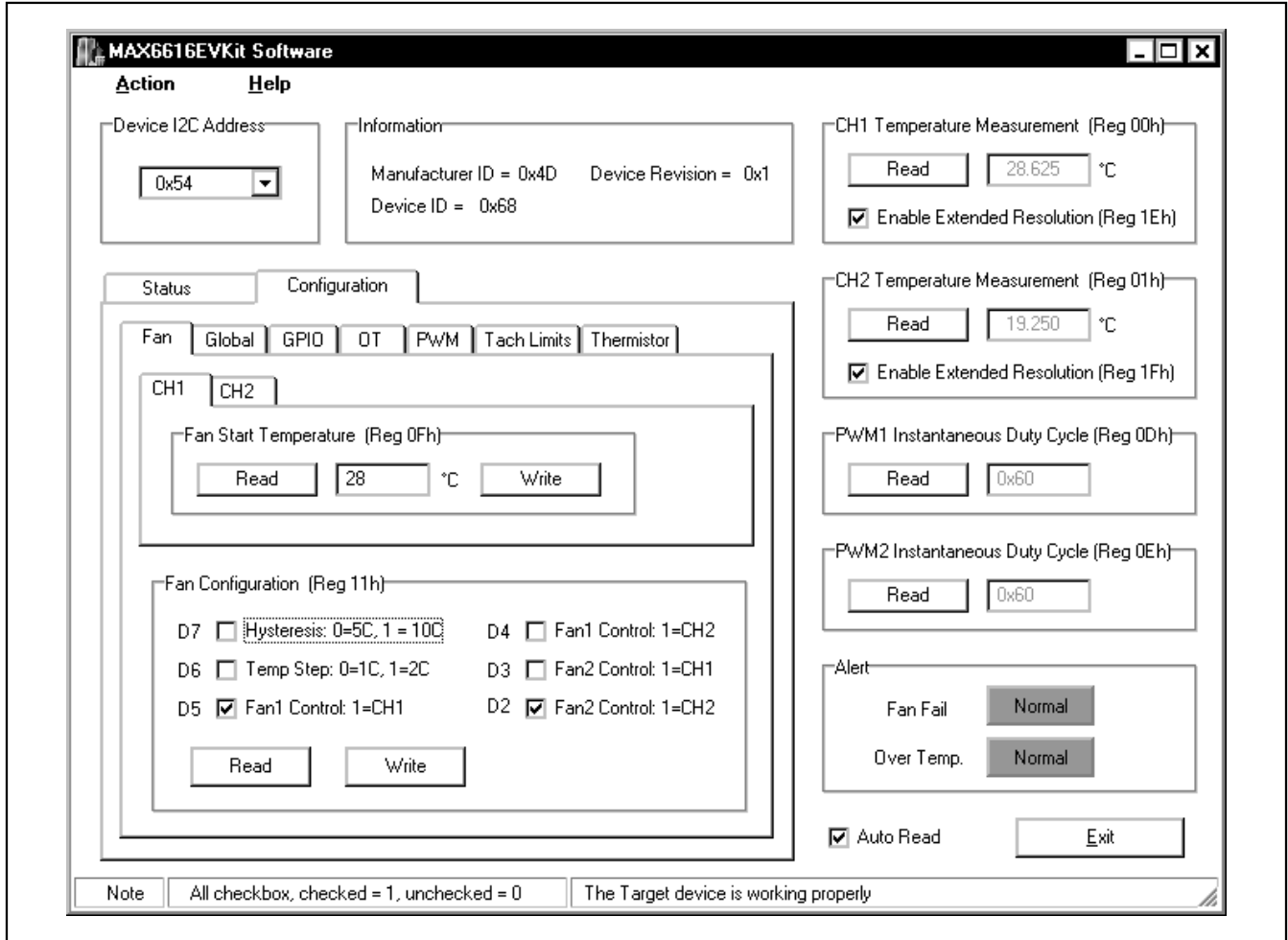

Figure 2. Configuration Tab Gives Seven Major Subtab Options

Device I²C Address

The **Device I²C Address** combo box shown at the top-left corner in Figure 1 displays the autodetected MAX6616 SMBus/I²C address.

Device Information

There are a total of 34 documented registers inside the MAX6616. The **Information** panel on the main window, which is next to the **Device I²C Address** combo box, shows the MAX6616's **Manufacturer ID** (RegFFh), **Device Revision** (RegFDh), and **Device ID** (RegFEh).

Temperature Measurement and PWM Instantaneous Duty Cycle

Six commonly used registers are shown on the right side of the main window. On the top is the **CH1 Temperature Measurement** panel that contains channel 1 temperature register (Reg00h) and channel 1 extended temperature register (Reg1Eh). Below it is the **CH2 Temperature Measurement** panel that contains channel 2 temperature register (Reg01h) and channel 2 extended temperature register (Reg1Fh). Following is the PWM1 instantaneous duty-cycle register (Reg0Dh) in the **PWM1 Instantaneous Duty Cycle** panel, and the PWM2 instantaneous duty-cycle register (Reg0Eh) in the **PWM2 Instantaneous Duty Cycle** panel.

MAX6616 Evaluation Kit/Evaluation System

Major Tabs

The rest of the 25 registers have been grouped into two major tabs named **Status** and **Configuration**.

The **Status** tab contains four subtabs: **Fan**, **GPIO**, **OT**, and **Tachometer**. The **Configuration** tab contains seven subtabs: **Fan**, **Global**, **GPIO**, **OT**, **PWM**, **Tach Limits**, and **Thermistor**. Some subtabs have only one register as shown in Figure 1, while others may have multiple registers or even multiple levels of subtabs as shown in Figure 2.

Alert Panel

The **Alert** panel located at the right bottom corner of the main window indicates the status of output pin **FAN_FAIL** and output pin **OT** (Figure 2).

Autoread Checkbox

There is an **Auto Read** checkbox at the bottom right side. By checking this checkbox, all the registers are read and updated every second.

Temperature Measurement

Both channel 1 and channel 2 temperature measurements are displayed on the main window. Channel 1 monitors the temperature of an external thermistor. Channel 2 monitors either the internal die temperature or the temperature of an external thermistor. The temperature measurements are capable of either 8-bit (Reg00h for channel 1 and Reg01h for channel 2) or 11-bit extended resolution (Reg00h plus Reg1Eh for channel 1, and Reg01h plus Reg1Fh for channel 2). 8-bit resolution results in temperature resolution of 1°C/LSB, and extended resolution results in temperature resolution of 0.125°C/LSB. Enable extended resolution by selecting the **Enable Extended Resolution** checkbox inside the **CH1 Temperature Measurement** panel and/or **CH2 Temperature Measurement** panel (Figure 2).

Automatic Fan-Control Setup Example

This section is an example of how to use the software to set up the MAX6616 for automatic fan control.

- 1) Select the **Configuration** tab and the **Fan** subtab. Check the **D2 (Fan2 Control)** and **D5 (Fan1 Control)** checkboxes inside the **Fan Configuration** panel and press the **Write** button. Fan1 is now controlled by temperature channel 1 and Fan2 is controlled by temperature channel 2.
- 2) Under the **Configuration** tab, select the **Global** subtab. Check the **D1 (CH2 source)** checkbox and press the **Write** button. Now temperature channel 1 monitors the external thermistor and temperature channel 2 monitors the internal die temperature.
- 3) On the main window, check the **Enable Extended Resolution** checkboxes for both **CH1** and **CH2 Temperature Measurement** panels, and click the **Auto Read** checkbox. The current temperature is updated every second.
- 4) Go back to the **Configuration** tab, select the **PWM** subtab, then **Duty Cycle Dynamics**. In the **Duty cycle Rate of Change** panel click the **Fan1** combo box and choose 0.125s. Do the same in the **Fan2** combo box and then press the **Write** button. This procedure causes the PWM duty cycle (and fan speed) to change relatively quickly for easy observation. (A slower duty-cycle rate of change is typically used in real system designs to minimize the audibility of fan-speed changes.)
- 5) Since the default POR values of both channels' fan-start temperatures are 0, the fans should already be operating. To stop them, set both channels' fan-start temperatures at least 10 degrees higher than the current temperature readings.
- 6) Select the **Fan** subtab under the **Configuration** tab. At the top of the subtab are the **Fan Start Temperature** panels for both CH1 and CH2. Individually set both temperature channels' fan-start temperatures to values at least 4°C higher than the current temperature readings, and press the **Write** button of each panel.
Wait until the fans have stopped. Observe the instantaneous duty cycles for both PWM1 and PWM2 decreasing to zero.
Individually set both temperature channels' fan-start temperatures two degrees higher than the current temperature and press the **Write** button of each panel.
- 7) Use your finger or other source to heat the MAX6616 (U1) or the external thermistor (R7) on the evaluation board. When the temperature rises above the fan-start temperature for a given sensor, the corresponding fan begins spinning.

MAX6616 Evaluation Kit/Evaluation System

Detailed Description of Hardware

MAX6616EVCMODU Evaluation System

The MAX6616 EV system consists of a MAX6616 EV kit and the Maxim CMODUSB command module.

CMODUSB Command Module

The CMODUSB uses a proprietary design to provide SPI™- and I²C-compatible interfaces to demonstrate various Maxim devices. Maxim reserves the right to change the implementation of this module at any time with no advance notice.

CMODUSB Power Supply

The CMODUSB board uses a MAX1658 linear regulator. Jumper J1 selects between the 5V DC voltage that comes from the USB connector or the MAX1658's regulated 3.3V output voltage.

Set the CMODUSB jumper J1 to position 2-3 (3.3V) to evaluate the MAX6616 EV kit.

MAX6616 EV Kit

The MAX6616 EV kit board can be obtained separately without the CMODUSB command module and provides a proven layout for evaluating the MAX6616. The MAX6616AEG (U1) is powered from V_{CC}. The user can change the power-supply V_{CC} voltage level from +3.0V to +5.5V. Make sure to remove the shunt of jumper JU4 to use a dedicated power supply to evaluate the MAX6616.

With two SMBus/I²C slave address select pins, ADD1 and ADD0, the MAX6616's device address can be set to one of nine different values by changing the combination of jumper JU1 (see Table 1).

Table 1. SMBus/I²C Slave Address

JUMPER	SHUNT POSITION	ADDRESS
JU1	1-3, 2-4	1001 110
	2-4	1001 101
	3-5, 2-4	1001 100
	1-3	0101 011
	Open*	0101 010
	3-5	0101 001
	1-3, 4-6	0011 010
	4-6	0011 001
	3-5, 4-6	0011 000

*Default configuration.

The MAX6616 has six GPIO ports. GPIO0 has a POR control pin named PRESET. This feature allows the GPIO0 default state POR to be controlled using jumper JU2 as shown in Table 2.

SPI is a trademark of Motorola, Inc.

Table 2. GPIO0 POR State

JUMPER	SHUNT POSITION	GPIO0 POR STATE
JU2	1-2*	HIGH
	2-3	LOW

*Default configuration.

For user convenience, the MAX6616 EV kit brings out all six GPIO pins as well as another two output pins, FAN_FAIL and \overline{OT} , through ten-pin header J7. Table 3 shows the pin descriptions for J7.

Table 3. J7 Pin Description

PIN NUMBER	PIN NAME
1	GPIO0
2	GPIO1
3	GPIO2
4	GPIO3
5	GPIO4
6	GPIO5
7	\overline{OT}
8	FAN_FAIL
9	GND
10	GND

*Default configuration.

The MAX6616 can be powered by either the CMODUSB or an external power supply. The power source is selected using the shunt on jumper JU4 as shown in Table 4.

Table 4. Power-Supply Selection

JUMPER	SHUNT POSITION	POWER-SUPPLY SOURCE
JU4	1-2*	Powered by CMODUSB module
	Open	Dedicate power supply, connect to VCC pad

*Default configuration.

JU3 is an uninstalled jumper that connects VCC and VDD. By default, the two pins of JU3 are connected together with a trace on the circuit board. If desired, the trace may be cut, thus separating VCC and VDD. This allows, for example, connecting the pullups to a voltage other than VCC or measuring the supply current of the board.

MAX6616 Evaluation Kit/Evaluation System

Evaluate: MAX6616

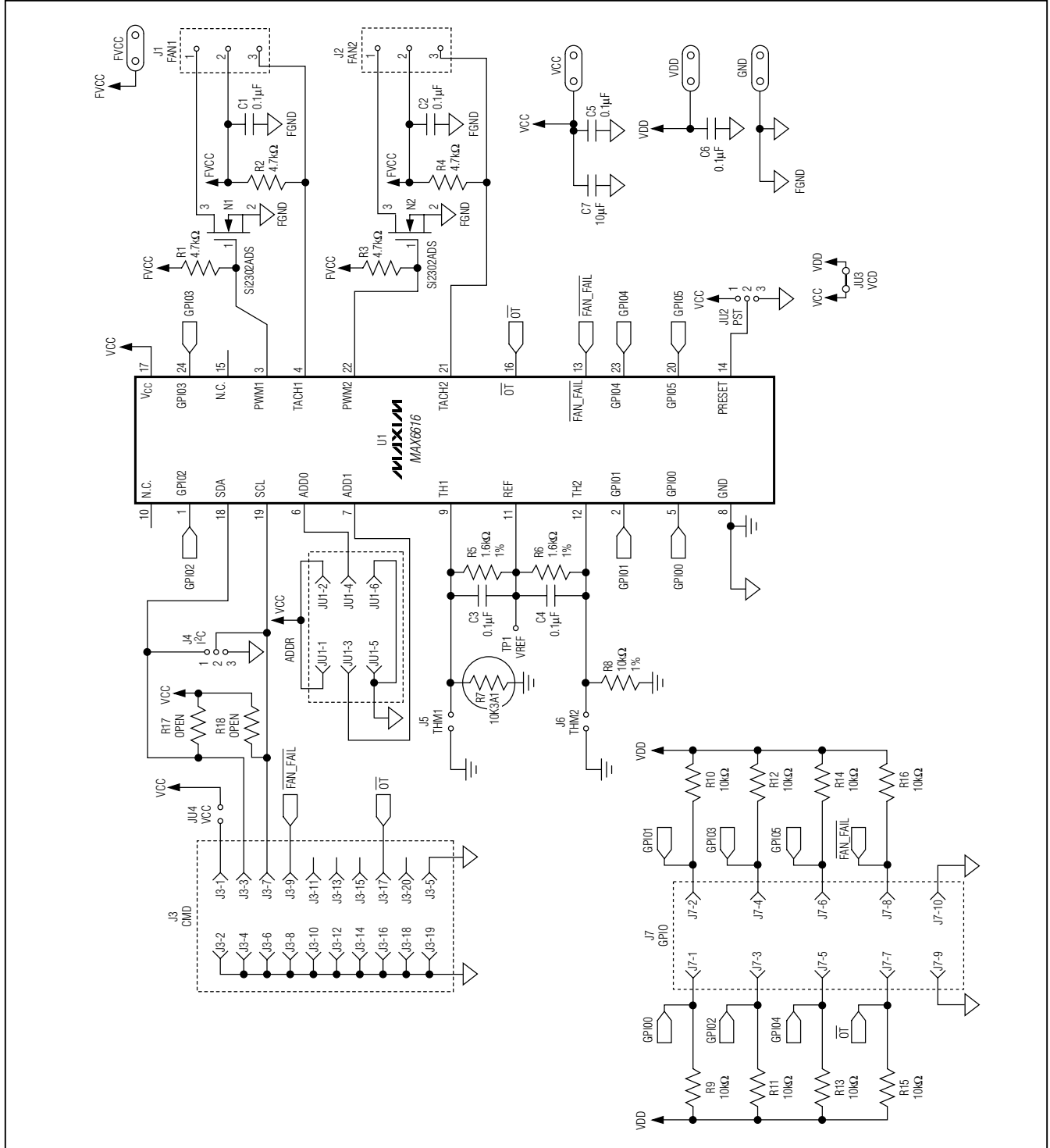

Figure 3. MAX6616 EV Kit Schematic

MAX6616 Evaluation Kit/Evaluation System

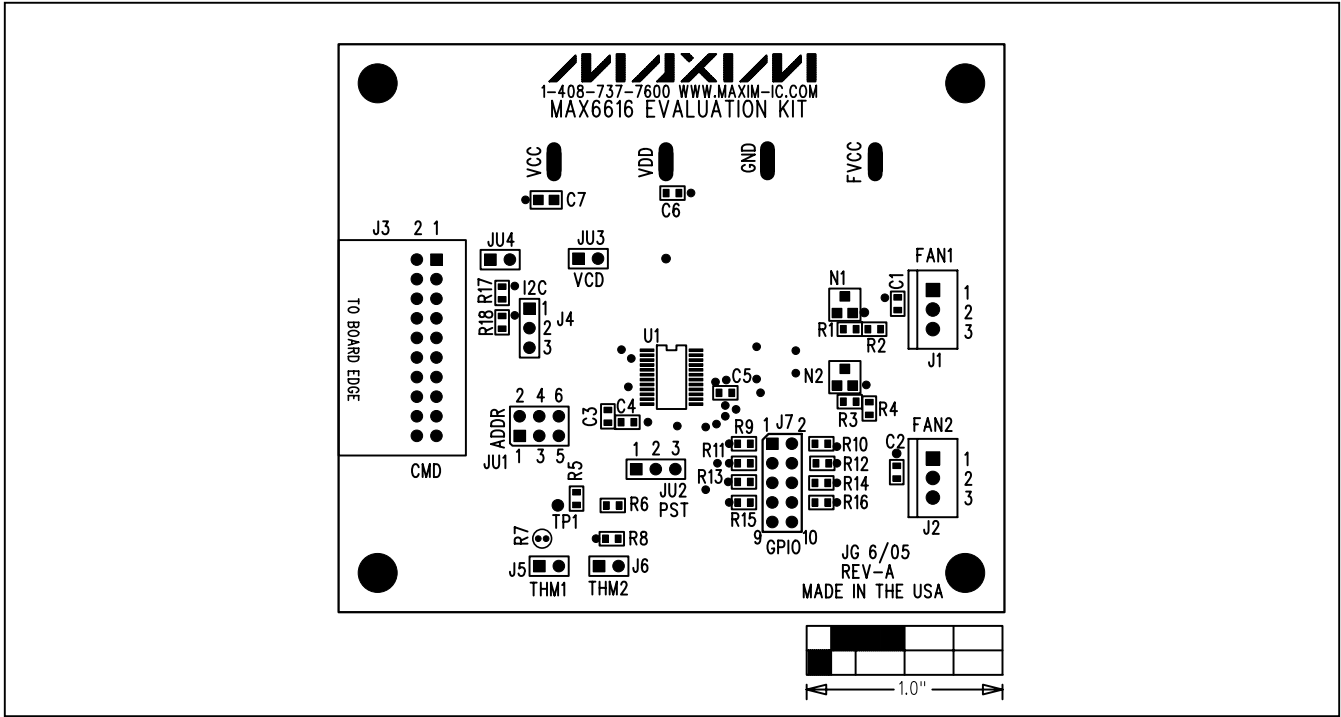

Figure 4. MAX6616 EV Kit Component Placement Guide—Component Side

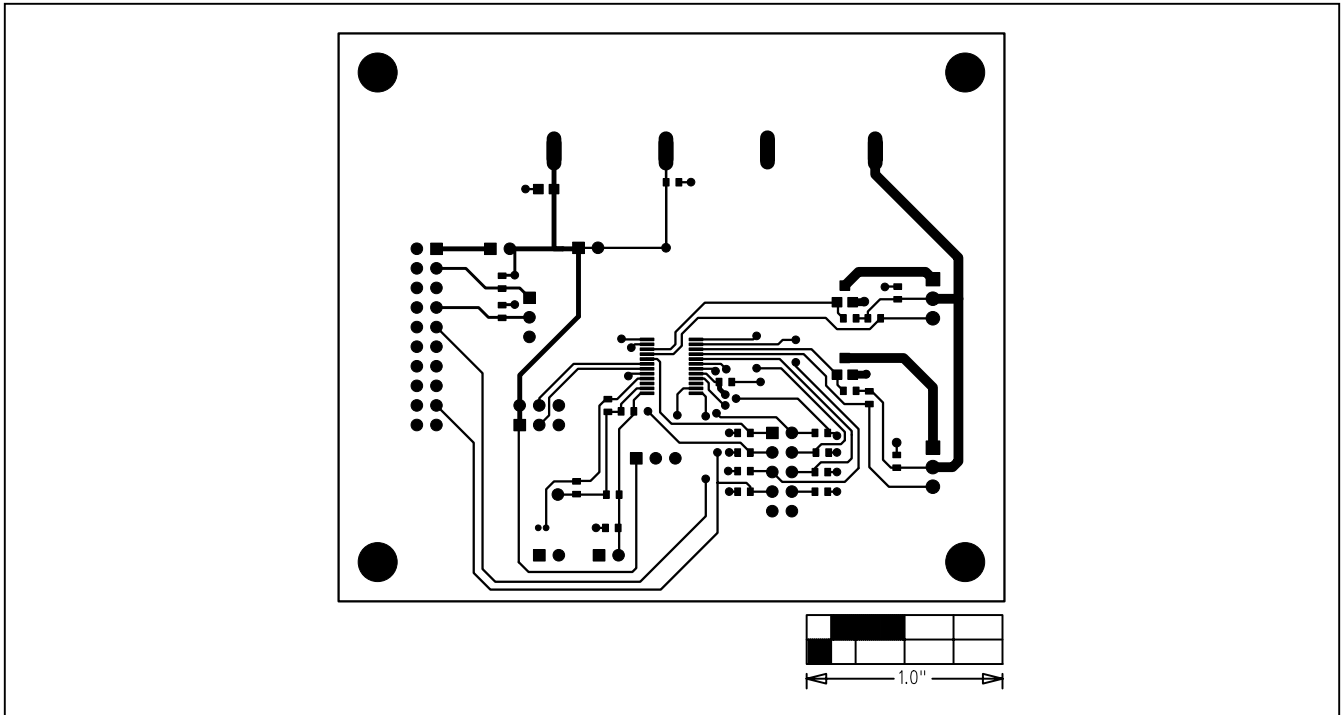

Figure 5. MAX6616 EV Kit PC Board Layout—Component Side

MAX6616 Evaluation Kit/Evaluation System

Evaluate: MAX6616

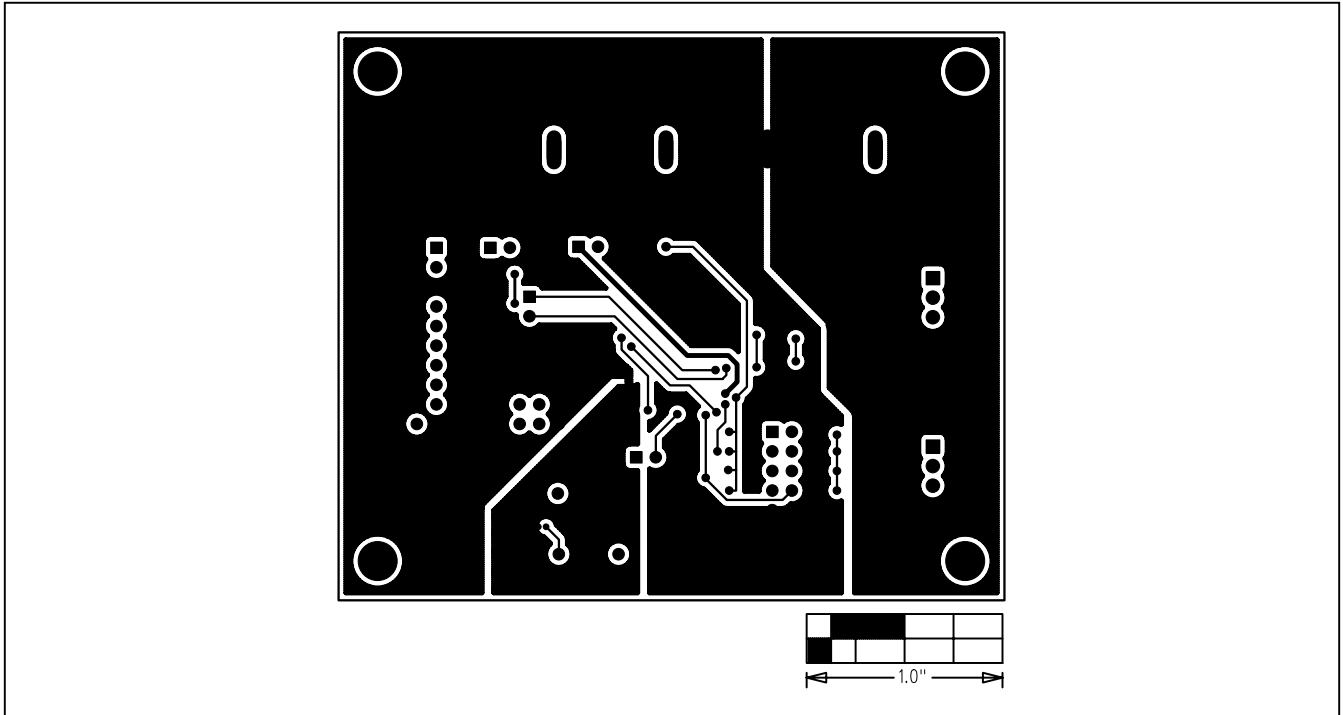

Figure 6. MAX6616 EV Kit PC Board Layout—Solder Side

Maxim cannot assume responsibility for use of any circuitry other than circuitry entirely embodied in a Maxim product. No circuit patent licenses are implied. Maxim reserves the right to change the circuitry and specifications without notice at any time.

Maxim Integrated Products, 120 San Gabriel Drive, Sunnyvale, CA 94086 408-737-7600 _____ 9