

LUMA

PART NUMBER  
SSI-LXR4915SYD-150

REV.  
C

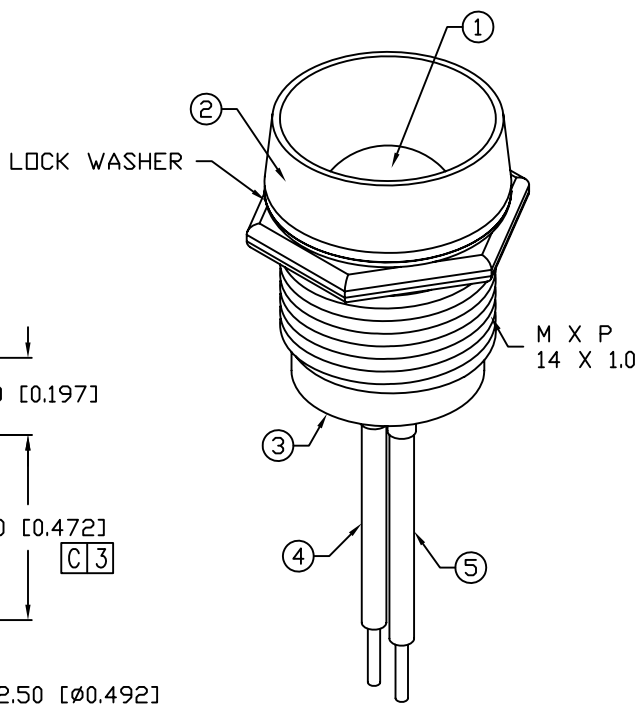
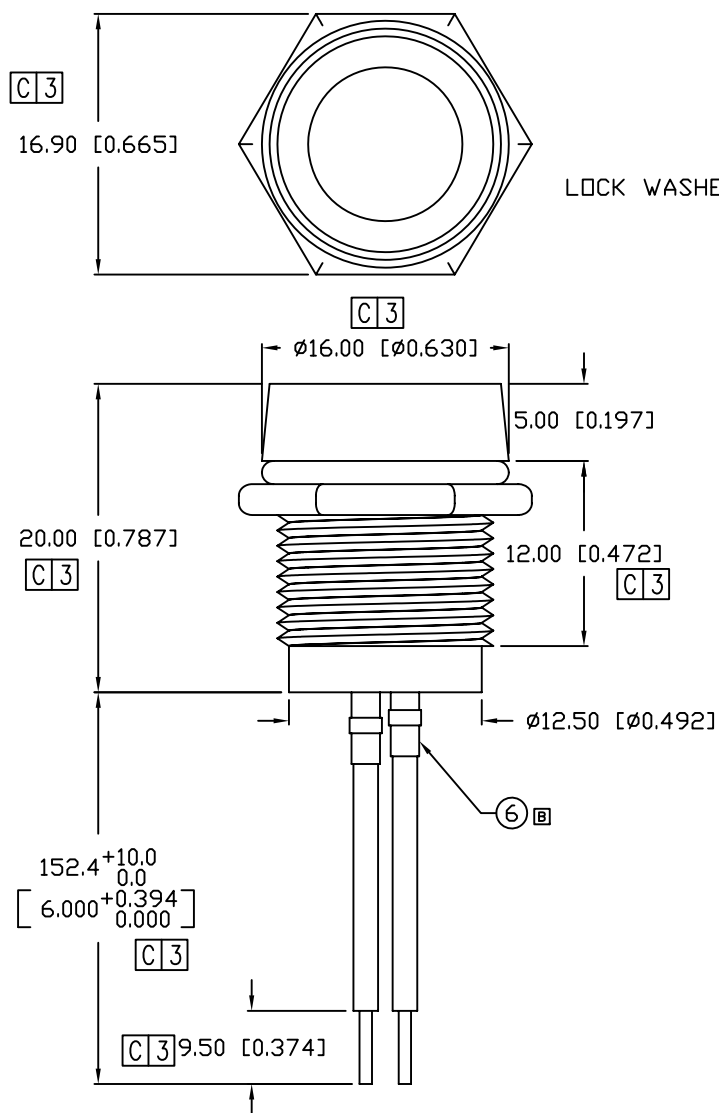

REV.	E.C.N. NUMBER AND REVISION COMMENTS	DATE
A	E.C.N. #10857.	4.25.02
B	E.C.N. #10907.	9.17.02
C	E.C.N. #10919.	10.22.02

ELECTRO-OPTICAL CHARACTERISTICS  $T_A=25^{\circ}\text{C}$   $I_f=20\text{mA}$

PARAMETER	MIN	TYP	MAX	UNITS	TEST COND
PEAK WAVELENGTH		590		nm	
FORWARD VOLTAGE		2.1	2.5	$V_f$	
REVERSE VOLTAGE	5.0			$V_r$	$I_r=100\mu\text{A}$
AXIAL INTENSITY		350		mcd	$I_f=20\text{mA}$
VIEWING ANGLE		60		2x theta	
EMITTED COLOR:	YELLOW				
EPOXY LENS FINISH:	YELLOW DIFFUSED				

LIMITS OF SAFE OPERATION AT 25°C

PARAMETER	MAX	UNITS
PEAK FORWARD CURRENT*	150	mA
STEADY CURRENT	30	mA
POWER DISSIPATION	105	mW
DERATE FROM 25°C	-1.2	mW/°C
OPERATING, STORAGE TEMP.	-40 TO +85	°C

\*  $t < 10\mu\text{s}$

NOTES:

1. SSL-LX100133SYD, YELLOW LED UN CUT LEADS.
2. SSI-LXR4915, CHROME HOUSING.
3. NEOPRENE RUBBER BUSHING.
4. ANODE LEAD: LXP-WST24RDT0C, 24 AWG STRANDED, RED INSULATION, CUT 142mm LONG, STRIP 3mm & 9.5mm.
5. CATHODE LEAD: LXP-WST24BLT0C, 24 AWG STRANDED, BLACK INSULATION, CUT 142mm, STRIP 3mm & 9.5mm.
6. LXP-HEATSHRINK-2; 1/16" X 37mm (2 PCS.)
7. LED IS SECURED INSIDE HOLDER WITH UV GLUE. THEN, INSERT BUSHING.

UNCONTROLLED DOCUMENT

\*UNLESS OTHERWISE SPECIFIED TOLERANCES PER DECIMAL PRECISION ARE: X=±1 (±0.039), X.X=±0.5 (±0.020), X.XX=±0.25 (±0.010), X.XXX=±0.127 (±0.005). LEAD SIZE=±0.05 (±0.002), LEAD LENGTH=±0.75 (±0.030). MIN.= +DECIMAL PRECISION MAX.= +0.00 -DECIMAL PRECISION

REV.	PART NUMBER
C	SSI-LXR4915SYD-150

10mm, 590nm AlInGaP YELLOW LED PANEL INDICATOR,  
YELLOW DIFFUSED LENS, 6" WIRE LEADS.

**CONFIDENTIAL INFORMATION**  
THE INFORMATION CONTAINED IN THIS DOCUMENT IS THE PROPERTY OF LUMEX INC. EXCEPT AS SPECIFICALLY AUTHORIZED IN WRITING BY LUMEX INC., THE HOLDER OF THIS DOCUMENT SHALL KEEP ALL INFORMATION CONTAINED HEREIN CONFIDENTIAL AND SHALL PROTECT SAME IN WHOLE OR IN PART FROM DISCLOSURE AND DISSEMINATION TO ALL THIRD PARTIES.

**RELIABILITY NOTE**  
OUR MANY YEARS OF EXPERIENCE DATA ACCUMULATION INDICATE THAT SOLDER HEAT IS A MAJOR CAUSE OF EARLY AND FUTURE FAILURE. PLEASE PAY ATTENTION TO YOUR SOLDERING PROCESS.



425 N. GARY AVE.  
CAROL STREAM, IL 60188-4900  
PHONE: +1.800.278.5666  
FAX: +1.630.315.2152  
WEB: WWW.ITWCS.COM

DRAWN BY:	CHECKED BY:	APPROVED BY:	DATE:
BC			1.2.02
			PAGE: 1 OF 1
			SCALE: N/A