

THIS DRAWING IS UNPUBLISHED. RELEASED FOR PUBLICATION, 19 .
 © COPYRIGHT 19 BY AMP INCORPORATED. ALL INTERNATIONAL RIGHTS RESERVED.

PROD	LOC	DIST	P	F	ZONE	LTR	DESCRIPTION	DATE	APPD
3349	DF	X0				E	REV & REDRAWN; 0600-5735-96 CT	3-97	JW

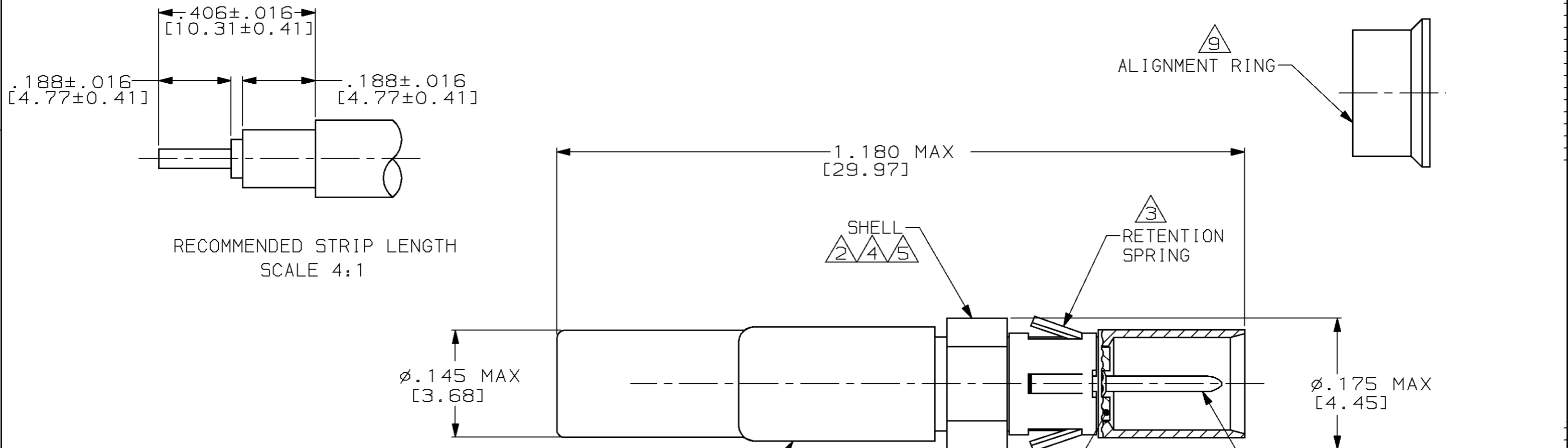

RECOMMENDED STRIP LENGTH
SCALE 4:1

- ① MATERIAL: PTFE PER ASTM-D-1457.
- ② MATERIAL: BRASS PER ASTM-B-16.
- ③ MATERIAL: STAINLESS STEEL PER QQ-S-766.
- ④ FINISH: NICKLE PLATE PER QQ-N-290.
- ⑤ FINISH: DURAGOLD PLATE.
- ⑥ FINISH: TIN PLATE PER ASTM-B-545.
- 7. FOR USE WITH: RG-178U DBL BRAID, 196/U, MALCO #250-3908-0000 & TENSOLITE #30850/81T-1 CABLE.
- 8. .180 [4.57] MIN DIA HOLE REQUIRED FOR CONTACT TO FEED THROUGH P.C. BOARD.
- ⑨ ALIGNMENT RING IS USED TO STABILIZE CONTACT IN THE HOUSING CAVITY; OTHERWISE DISCARD.
- 10. SEE I.S. 2923 AND USE CRIMPING TOOL 220215-1.

227605-1
PART NO

DO NOT SCALE PRINT. UNLESS SPECIFIED DIMENSIONS IN INCHES [mm] TOLERANCES ON: 2 PLC DEC ± _____ 3 PLC DEC ± _____ ANGLES ± _____	DR 3-4-97 C.C. THOMAS	AMP AMP Incorporated Harrisburg, PA 17105-3608
	CHK 3-4-97 J. WEAVER	
	APPD 3-4-97 J. WEAVER	
	RLSE 3-4-97 C.C. THOMAS	
MATERIAL ①②③	PRODUCT SPEC -	NAME CONTACT, SOCKET, COAXIAL, MICROMINIATURE
FINISH ④⑤	APPLICATION SPEC -	SIZE B CAGE CODE 00779 DRAWING NO 227605-1
	WEIGHT -	SCALE 8:1 SHEET 1 OF 1