

THIS DRAWING IS UNPUBLISHED. RELEASED FOR PUBLICATION
 © COPYRIGHT BY TYCO ELECTRONICS CORPORATION. ALL INTERNATIONAL RIGHTS RESERVED.

LOC	DIST	REVISIONS			
P	LTR	DESCRIPTION	DATE	DWN	APVD
AF	50	S1	REVISED PER ECR-09-000368	20JAN09	HMR DD

- CONTINUOUS STRIP ON REEL.
- WIRE SIZE IS [#20-#16] AWG
- INSULATION RANGE IS 1.90-2.79 [.075-.110] DIA.
- PREPRODUCTION - F.A.S.R. REQUIRED.

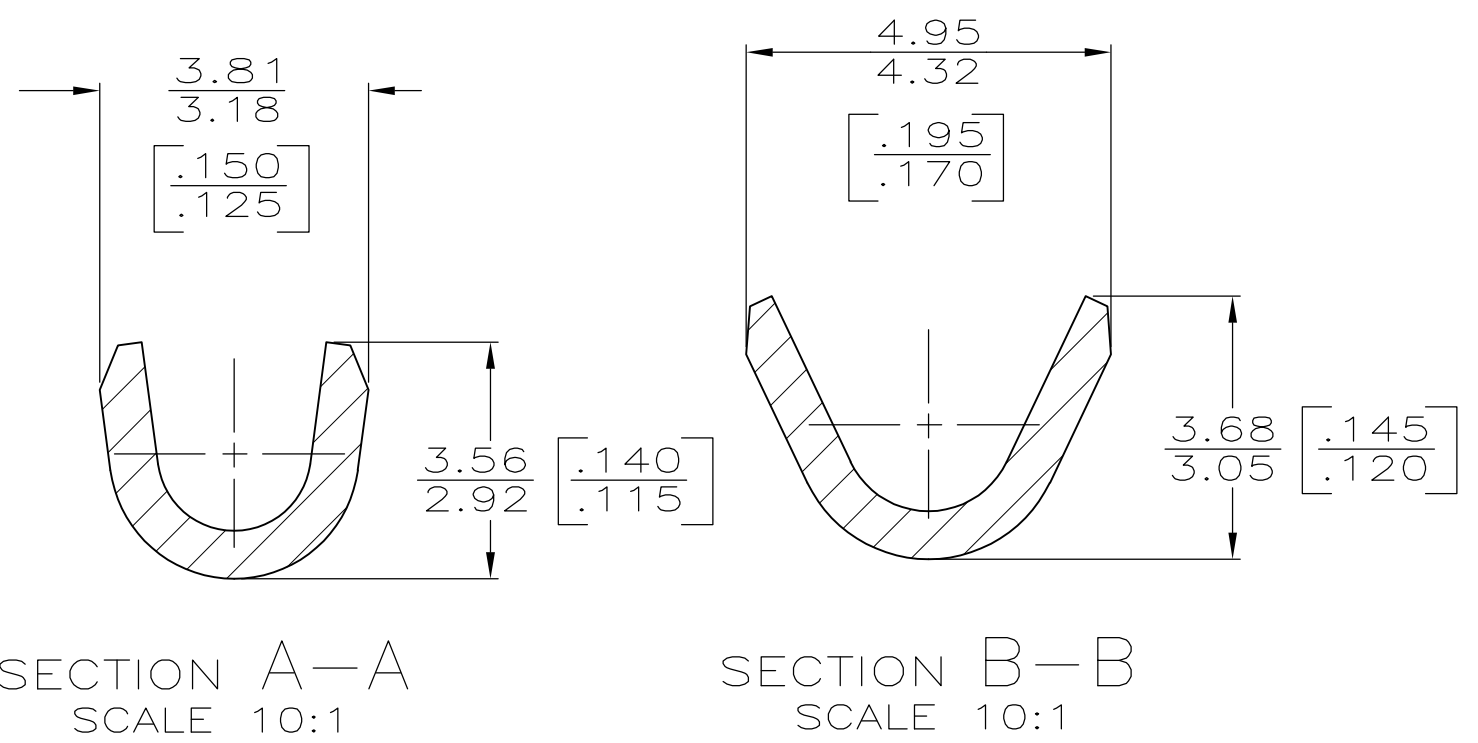
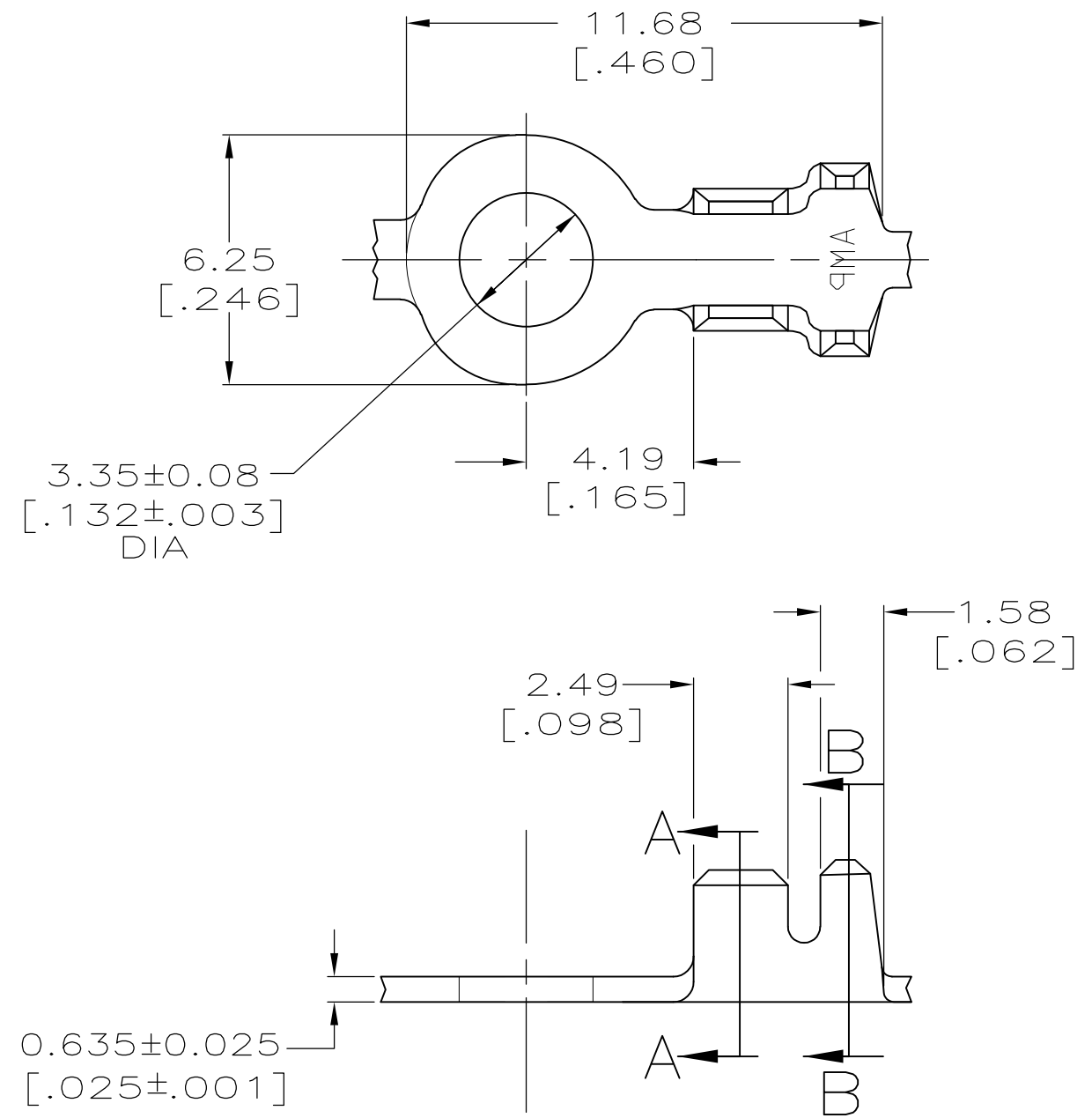

OBSOLETE	-0.002032 [.000080] MIN TIN	42721-2
		42721-1
	FINISH	PART NO.

THIS DRAWING IS A CONTROLLED DOCUMENT.		DWN 06/JUL/95 PHILLIP M FORTNEY	Tyco Electronics Corporation Harrisburg, PA 17105-3608	
DIMENSIONS: INCHES		CHK 06/JUL/95 MICHAEL S FEHER	NAME	
TOLERANCES UNLESS OTHERWISE SPECIFIED:		APVD 06/JUL/95 D DECKER	RING TONGUE	
0 PLC ± - 1 PLC ± - 2 PLC ± 0.38 [.015] 3 PLC ± - 4 PLC ± - ANGLES ± -		PRODUCT SPEC	SIZE	CAGE CODE
MATERIAL: 082 BRASS		APPLICATION SPEC	DRAWING NO: C-42721	
FINISH: SEE TABLE		WEIGHT: -	RESTRICTED TO: -	
CUSTOMER DRAWING		SCALE: 6:1	SHEET: 1 OF 1	REV: S1