

Test Procedure for the STK5Q4U352JGEVB Evaluation Board

Description of each pin

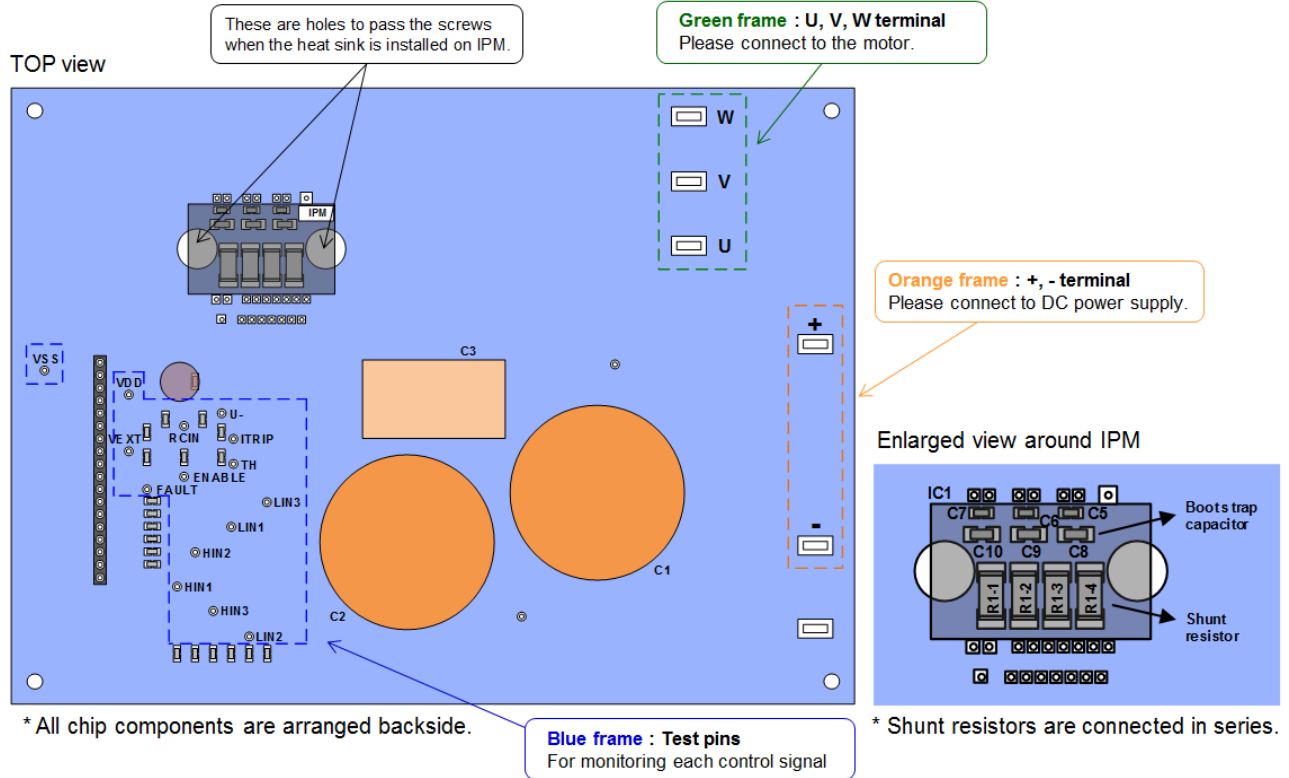

Enlarged view around test pins

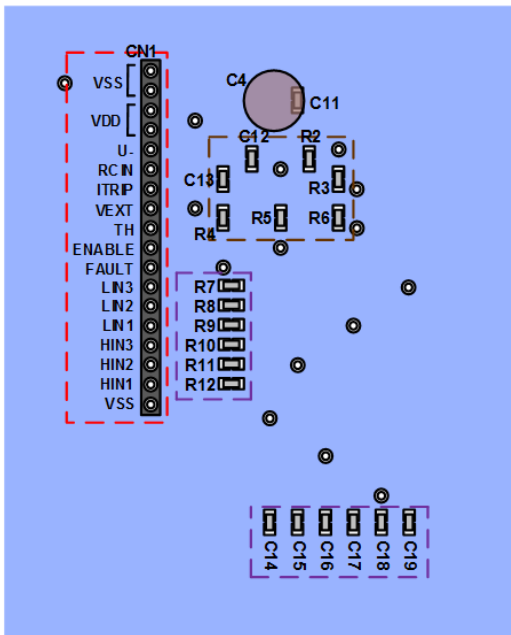

* All chip components are arranged backside.

Red frame : Connector
For the connection to the control part

Vext terminal is connected pull-up resistor for TH, FAULT and ENABLE pins.
Please impress arbitrary voltage to this terminal.

Purple frame : Low pass filter for signal input pins

Resistor R7-R12 : 100Ω
Capacitor C14-C19 to VSS : 100pF

Brown frame :

R4, R5, R6 : Pull-up resistor to VEXT
R2, C12 : Fault clear time setting
R3, C13 : Time constant setting for ITRIP

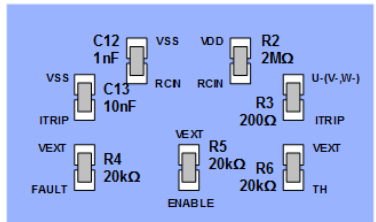

Operation procedure

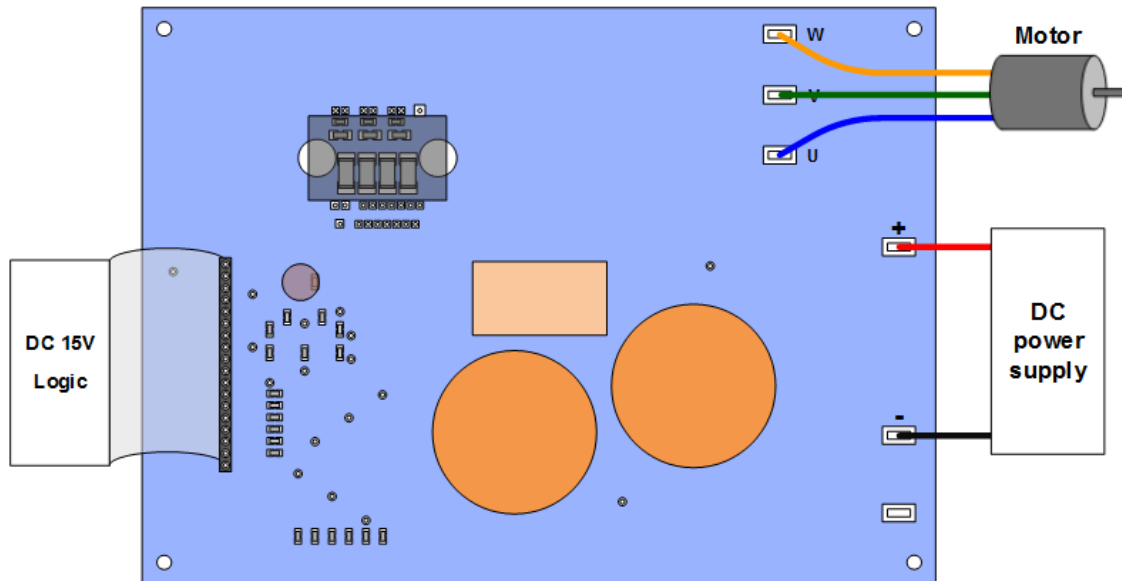

- Step1:** Please connect IPM, each power supply, logic parts, and the motor to the evaluation board, and confirm that each power supply is OFF at this time.
- Step2:** Please impress the power supply of DC15V.
- Step3:** Please perform a voltage setup according to specifications, and impress the power supply between the "+" and the "-" terminal.
- Step4:** By inputting signal to the logic part, IPM control is started.
(Therefore, please set electric charge to the boot-strap capacitor of upper side to turn on lower side IGBT before running.)

※ When turning off the power supply part and the logic part, please carry out in the reverse order to above steps.